

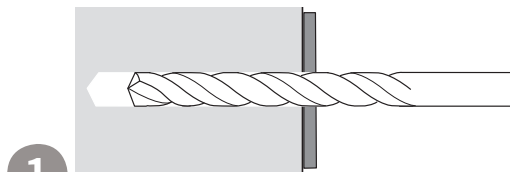

# HEAVY DUTY ANCHOR - SZ-S

## Installation:

For fixing of medium to heavy duty applications where extra high degree of load capacity is required in both cracked and non-cracked concrete



**1** Drill a hole with correct diameter and depth through fixture and into the concrete

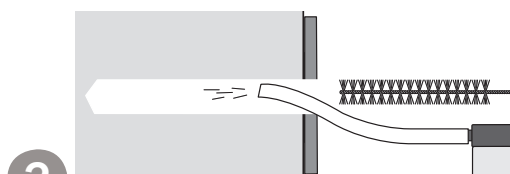

**2** Clean the drilled hole thoroughly

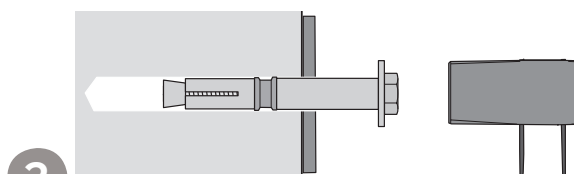

**3** Hammer in the Heavy Duty Anchor as through fixing. Tighten the anchor to the fixture using a torque wrench

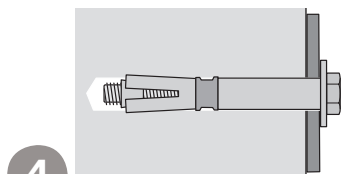

**4** The installation is finished



## Materials:

Heavy Duty Anchor SZ-S is zinc plated min. 5 µm in accordance with EN ISO 4042.

Bolt (hex cap screw): 8.8 steel in accordance with EN ISO 898-1

Washer: Steel in accordance with EN 10139

Threaded cone: 8.8 steel in accordance with EN ISO 898-2

Expansion sleeve: Steel in accordance with EN 10139

Distance sleeve: Precision steel tubes in accordance with DIN 2394/2393

## Approvals:

Heavy Duty Anchor type SZ-S is CE-marked and have European Technical Approval (ETA) in option 1 (ETA -02/0030).

Heavy Duty Anchor type SZ-S is fire tested to 120 minutes.

Shock approval

VdS approval

## Advantages:

- High Steel strength
- Easy installation – Through fixing.
- Approved for use in cracked concrete.
- Can also be supplied with threaded bolt and nut or countersunk head.
- Anchorage can be designed in Expandet Calculation Software.



EXPANDET SCREW ANCHORS A/S  
Svendebuen 2-6  
P.O. Box 59  
DK-3230 Græsted  
Denmark

Telephone: +45 70 22 79 79  
Telefax: +45 70 22 79 89

Version 06.012

www.expandet.com  
expandet@expandet.dk

Graphic: Vedkom /Expandet  
©Expandet Screw Anchors A/S, 2006  
All rights reserved



**HEAVY DUTY ANCHOR - SZ-S**

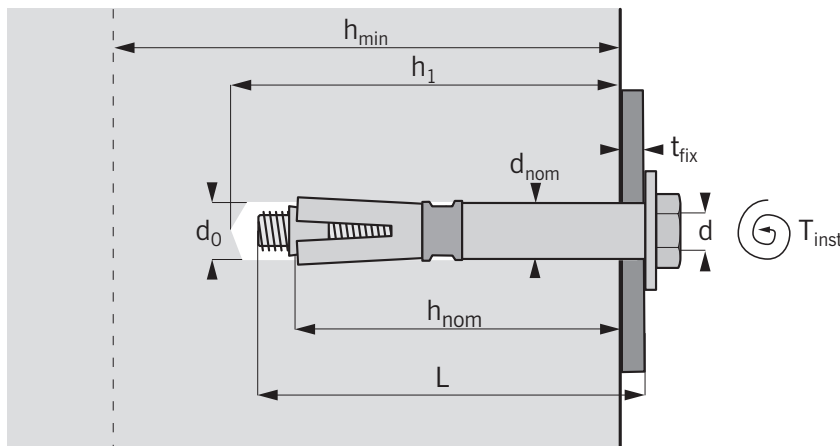

Heavy Duty Anchor SZ-S, zinc plated																
Type	Dimensions				Fixing								Load Capacities			
	d	d <sub>nom</sub>	L	t <sub>fix</sub>	d <sub>0</sub>	h <sub>1</sub>	h <sub>nom</sub>	h <sub>ef</sub>	T <sub>inst</sub>	h <sub>min</sub>	S <sub>min</sub>	C <sub>min</sub>	Uncracked concrete N <sub>Rd</sub>	Cracked concrete V <sub>Rd</sub>	Cracked concrete N <sub>Rd</sub>	Cracked concrete V <sub>Rd</sub>
Heavy Duty Anchor SZ	Bolt diameter mm	Outside diameter of anchor mm	Anchor length mm	Thickness of fixture (Max.) mm	Drill hole diameter mm	Depth of drilled hole (Min.) mm	Anchor embedment depth mm	Effective anchorage depth mm	Required setting torque Nm	Thickness of concrete member, min., mm	Minimum allowable spacing mm	Min. allowable edge distance mm	Design load tension kN*	Design load shear kN <sup>◇</sup>	Design load tension kN*	Design load shear kN <sup>◇</sup>
SZ 10/10	M 6	10	70	10	10	65	60	50	12	100	100	50	8,0	14,1	3,3	14,1
SZ 10/30	M 6	10	90	30	10	65	60	50	12	100	100	50	8,0	14,1	3,3	14,1
SZ 10/50	M 6	10	110	50	10	65	60	50	12	100	100	50	8,0	14,1	3,3	14,1
SZ 12/10	M 8	12	80	10	12	80	70	60	30	120	120	60	10,6	23,9	8,0	22,3
SZ 12/30	M 8	12	100	30	12	80	70	60	30	120	120	60	10,6	23,9	8,0	22,3
SZ 12/50	M 8	12	120	50	12	80	70	60	30	120	120	60	10,6	23,9	8,0	22,3
SZ 15/15	M10	15	100	15	15	95	85	71	50	140	175	70	16,6	38,5	10,6	28,7
SZ 15/25	M10	15	110	25	15	95	85	71	50	140	175	70	16,6	38,5	10,6	28,7
SZ 15/45	M10	15	130	45	15	95	85	71	50	140	175	70	16,6	38,5	10,6	28,7
SZ 18/10	M12	18	110	10	18	105	95	80	80	160	200	80	20,0	48,0	17,7	34,3
SZ 18/20	M12	18	120	20	18	105	95	80	80	160	200	80	20,0	48,0	17,7	34,3
SZ 18/40	M12	18	140	40	18	105	95	80	80	160	200	80	20,0	48,0	17,7	34,3
SZ 24/20	M16	24	140	20	24	130	120	100	100	200	220	100	26,6	67,2	24,0	48,0
SZ 24/50	M16	24	170	50	24	130	120	100	100	200	220	100	26,6	67,2	24,0	48,0

- ♦ Design resistance for tension is valid for a single anchor in concrete C20/25 not influenced by edge distance and/or spacing:  $C \geq 1,5 h_{ef}$  and  $S \geq 3 h_{ef}$ ,  $\Psi_{re,N} = 1$  (Normal reinforcement according to ETAG 001, Annex C - 5.2.2.4).
- ◇ Design resistance for shear is valid for a single anchor in concrete  $\geq C20/25$  not influenced by edge distance and/or spacing:  $C \geq 10 h_{ef}$  and  $S \geq 3 h_{ef}$ .

Combined resistance shall be verified if both tension and shear actions are applied. Se "Principles for Fastening" page 5 (Verification Method 2)

Partial safety factor for material ( $\gamma_m$ ) is included in accordance with product ETA. Partial safety factor for action ( $\gamma_f$ ) has to be applied in accordance with national building code. If no guidance for  $\gamma_f$  exists ETAG 001, Annex C recommends factor 1,35 for permanent action and factor 1,5 for variable action.

When calculating load capacity for anchor or anchorgroup use Expandet Calculation Software allowing for design with individual edge distance and spacing in accordance with ETAG 001, Annex C, Design Method A. Download Expandet Calculation Software for free at [www.expandet.com](http://www.expandet.com).

**Important:** See Expandet's "Principles for fastening" for general information on fastening as well as information on limited liability. (Can be downloaded at [www.expandet.com](http://www.expandet.com))

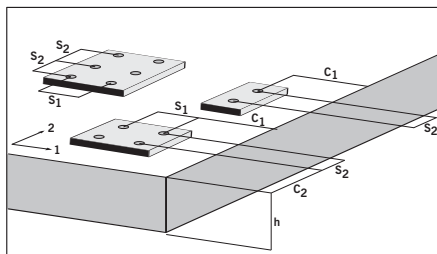

EXPANDET SCREW ANCHORS A/S  
Svendebuen 2-6  
P.O. Box 59  
DK-3230 Græsted  
Denmark

Telephone: +45 70 22 79 79  
Telefax: +45 70 22 79 89

Version 06.012

[www.expandet.com](http://www.expandet.com)  
[expandet@expandet.dk](mailto:expandet@expandet.dk)

Graphic: Vedkom /Expandet  
©Expandet Screw Anchors A/S, 2006  
All rights reserved

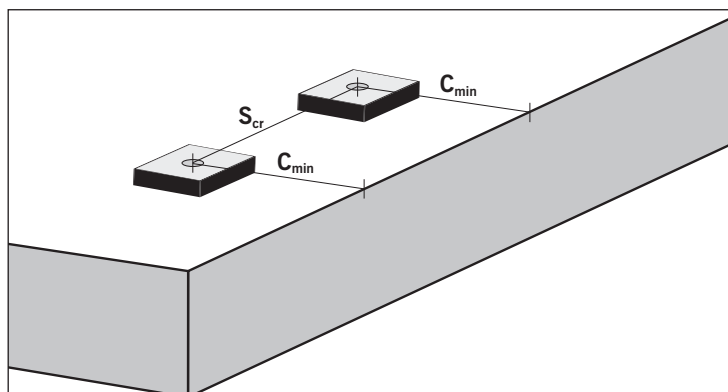

## HEAVY DUTY ANCHOR - SZ-S

**Design shear load capacity for a single anchor at minimum edge distance ( $C_{min}$ )<sup>♦</sup>**

		M6	M8	M10	M12	M16
$V_{Rd,c}$ (cracked)	kN	2,31	3,35	4,64	6,14	9,78
$V_{Rd,c}$ (non-cracked)	kN	3,23	4,66	6,49	8,60	13,68
$C_{min}$	mm	50	60	70	80	100
$S_{cr}$	mm	100	120	175	120	220

♦ Design resistance for shear is valid at minimum edge distance in concrete C20/25 providing that characteristic spacing is  $\geq S_{cr}$ .

Partial safety factor for edge failure ( $\gamma_{mc}$ ) is included in accordance with product ETA. Use Expandet Calculation Software for calculation of load capacity for anchor and anchorage in accordance with ETAG 001, Annex C – Design Method A.

**Design shear load capacity for steel failure and resistance against bending (lever arm) for a single anchor<sup>◇</sup>**

		M6	M8	M10	M12	M16
$V_{Rd,s}$	kN	14,16	23,92	38,48	58,16	72,96
$M_{Rd}$	Nm	9,6	24	48	84	212

◇ Above design shear load capacities against bending include partial safety factor for material ( $\gamma_{ms}$ ) in accordance with product ETA.



EXPANDET SCREW ANCHORS A/S  
Svendebuen 2-6  
P.O. Box 59  
DK-3230 Græsted  
Denmark

Telephone: +45 70 22 79 79  
Telefax: +45 70 22 79 89

Version 06.012

www.expandet.com  
expandet@expandet.dk

Graphic: Vedkom/Expandet  
©Expandet Screw Anchors A/S, 2006  
All rights reserved

## EXPANDET SCREW ANCHORS A/S

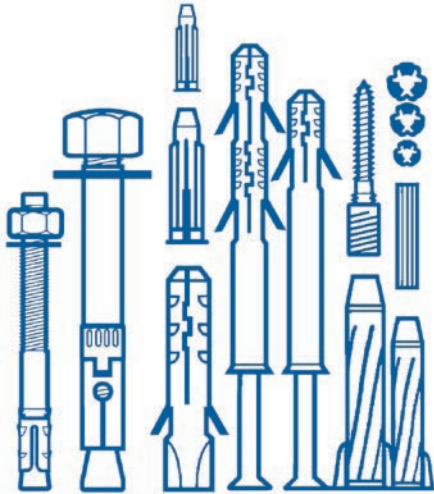

Expandet Screw Anchors A/S was established in 1955 and was pioneers in the field of fastener products for concrete and brickwork - being the first company to patent a fastener made in plastic. We are devoted to a constant development of our product range, which now covers the entire range of anchors and fasteners for both professional and DIY.

We have - with our base-material orientated colour code system - made it easy to choose the right anchor for the right base material

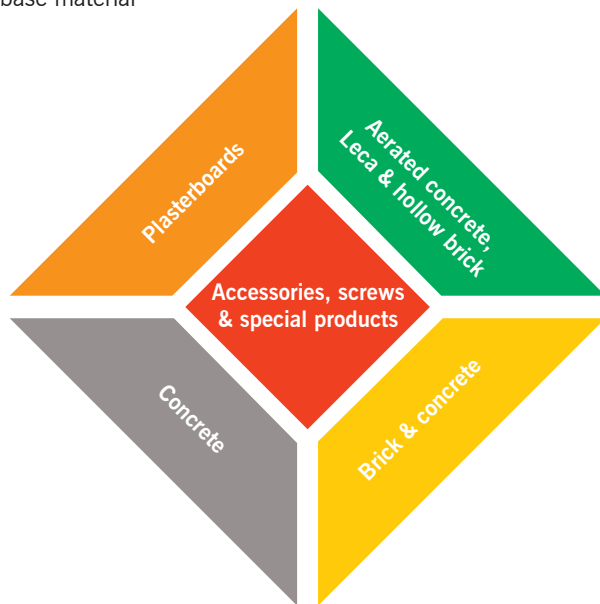

## EXPANDET CALCULATION SOFTWARE

Expandet Calculation Software offers the possibility for design of single anchors and anchors groups in concrete according to ETAG 001, Annex C with our range of products that are defined according to CC Method. This includes our range of anchor systems approved for structural connections with CE-marking.

Code	Unit	Definition
d	Mx	Bolt diameter
d <sub>nom</sub>	mm	Outside diameter of anchor
L	mm	Anchor length
L <sub>bolt</sub>	mm	Bolt / screw length
L <sub>thread</sub>	mm	Length of metric thread
L <sub>th</sub>	mm	Available internal thread length
L <sub>smin</sub>	mm	Minimum screw in depth
d <sub>o</sub>	mm	Drill hole diameter
h <sub>i</sub>	mm	Depth of drilled hole
h <sub>nom</sub>	mm	Anchor embedment depth
h <sub>er</sub>	mm	Effective anchorage depth
h	mm	Thickness of member (concrete, brickwall etc.)
h <sub>min</sub>	mm	Minimum thickness of member
h <sub>f</sub>	mm	Minimum cavity behind wall
t <sub>fix</sub>	mm	Thickness of fixture
b <sub>fix1,2</sub>	mm	Width of fixture: b <sub>fix1</sub> (direction 1) & b <sub>fix2</sub> (direction 2)
T <sub>inst</sub>	Nm	Required setting torque
S	mm	Spacing between anchors in an anchorage
S <sub>1</sub> ; S <sub>2</sub>	mm	Spacing between anchors in an anchorage: S <sub>1</sub> (direction 1) & S <sub>2</sub> (direction 2)
S <sub>cr,N</sub>	mm	Characteristic spacing for ensuring the transmission of the characteristic resistance of a single anchor in case of concrete cone failure
S <sub>cr,sp</sub>	mm	Characteristic spacing for ensuring the transmission of the characteristic resistance of a single anchor in case of splitting failure
S <sub>rec</sub>	mm	Recommended spacing (for full resistance)
S <sub>min</sub>	mm	Minimum allowable spacing
S <sub>cr</sub>	mm	Characteristic spacing at a defined edge distance
C	mm	Edge distance
C <sub>1</sub> ; C <sub>2</sub>	mm	Edge distance fra anchor to edge: C <sub>1</sub> (direction 1) & C <sub>2</sub> (direction 2)
C <sub>cr,N</sub>	mm	Characteristic edge distance for ensuring the transmission of the characteristic resistance of a single anchor in case of concrete cone failure
C <sub>cr,sp</sub>	mm	Characteristic edge distance for ensuring the transmission of the characteristic resistance of a single anchor in case of splitting failure
C <sub>rec</sub>	mm	Recommended edge distance (for full resistance)
C <sub>min</sub>	mm	Minimum allowable edge distance
C <sub>er</sub>	mm	Characteristic edge distance at a defined spacing
N <sub>Rd</sub>	kN	Design resistance, tension
N <sub>Rd,s</sub>	kN	Design resistance, tension (steel failure)
N <sub>Rd,p</sub>	kN	Design resistance, tension (pull out failure)
N <sub>Rd,c</sub>	kN	Design resistance, tension (concrete cone failure)
N <sub>Rd,sp</sub>	kN	Design resistance, tension (splitting failure)
V <sub>Rd</sub>	kN	Design resistance, shear
V <sub>Rd,s</sub>	kN	Design resistance, shear (steel failure)
V <sub>Rd,c</sub>	kN	Design resistance, shear (concrete pryout failure, concrete edge failure)
F <sub>Rd</sub>	kN	Design resistance, independent of load direction
M <sub>Rd</sub>	Nm	Design resistance, bending moment
γ <sub>M</sub>		Partial safety factor for material
γ <sub>Ms</sub>		Partial safety factor for material, steel failure
γ <sub>Mp</sub>		Partial safety factor for material, pull out failure
γ <sub>Mc</sub>		Partial safety factor for material, concrete cone failure
γ <sub>Msp</sub>		Partial safety factor for material, splitting failure
N <sub>Sd</sub>	kN	Design value of tensile actions acting on a single anchor or the fixture of an anchor group
V <sub>Sd</sub>	kN	Design value of shear actions acting on a single anchor or the fixture of an anchor group
γ <sub>f</sub>		Partial safety factor for actions
N <sub>rec</sub>	kN	Maximum recommended tension load
V <sub>rec</sub>	kN	Maximum recommended shear load
F <sub>rec</sub>	kN	Maximum recommended load, independent of load direction
f <sub>ck</sub>	N/mm <sup>2</sup>	Characteristic concrete compression strength measured on cylinders
f <sub>ck,cube</sub>	N/mm <sup>2</sup>	Characteristic concrete compression strength measured on cubes
F <sub>yk</sub>	N/mm <sup>2</sup>	Characteristic steel yield strength
F <sub>uk</sub>	N/mm <sup>2</sup>	Characteristic steel ultimate tensile strength



EXPANDET SCREW ANCHORS A/S  
Svendebuen 2-6  
P.O. Box 59  
DK-3230 Græsted  
Denmark

Telephone: +45 70 22 79 79  
Telefax: +45 70 22 79 89

Version 06.012

www.expandet.com  
expandet@expandet.dk

Graphic: Vedkom /Expandet  
©Expandet Screw Anchors A/S, 2006  
All rights reserved