

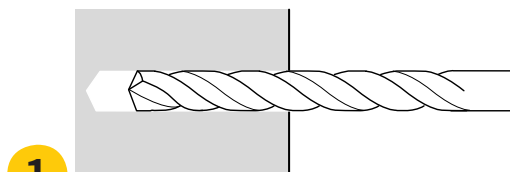

EXPANSION SHIELD

For fixing of heavy objects in concrete and solid brick

Installation:



1 Drill a hole with correct diameter and depth

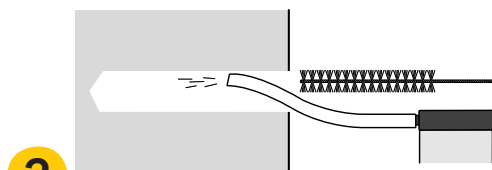

2 Clean the hole thoroughly

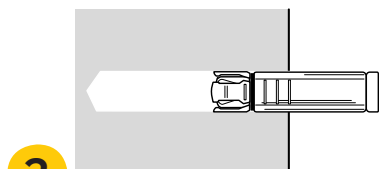

3 Insert the Expansion Shield flush with the wall

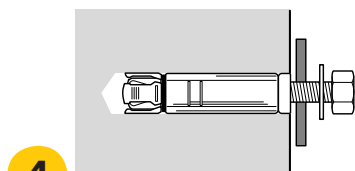

4 Mount the fixture with set screw, threaded rod or other metric screw and tighten to required setting torque

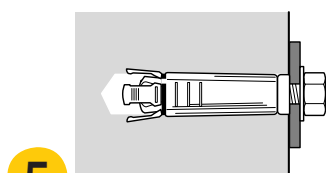

5 The installation is finished

Note Only use bolt diameter M6 and M8 in solid brick

Advantages:

- Free choice between set screw, threaded rod, bolt etc.
- High loads in massive materials.
- Fixture can be removed without affecting the anchor.
- Anchorage can be designed in Expandet Calculation Software.



Accessories:

Set screw, threaded bolts or threaded rods.

Materials:

Expandet Expansions Shield is produced in:
 Cone: 8.8 steel in accordance with EN 20898-2
 Shield: Cold formed steel, zinc plated min. 5 µm.
 Ferrule: Cold formed (EN 10205)
 Spring coil: DIN 17223 BL 1, class B
 Expansion Shield is also supplied in stainless steel A4.

Approvals:

Expansion Shield HAC M6-M12 together with metric thread in 8.8 steel has European Technical Approval (ETA) in option 8 (ETA-01/0012).



European Technical Approval - Option 8 for non-cracked concrete



EXPANDET SCREW ANCHORS A/S
 Svendebuen 2-6
 P.O. Box 59
 DK-3230 Græsted
 Denmark

Telephone: +45 70 22 79 79
 Telefax: +45 70 22 79 89

Version 06.012

www.expandet.com
 expandet@expandet.dk

Graphic: Vedkom /Expandet
 ©Expandet Screw Anchors A/S, 2006
 All rights reserved



EXPANSION SHIELD



European Technical Approval
- Option 8
for non-cracked concrete

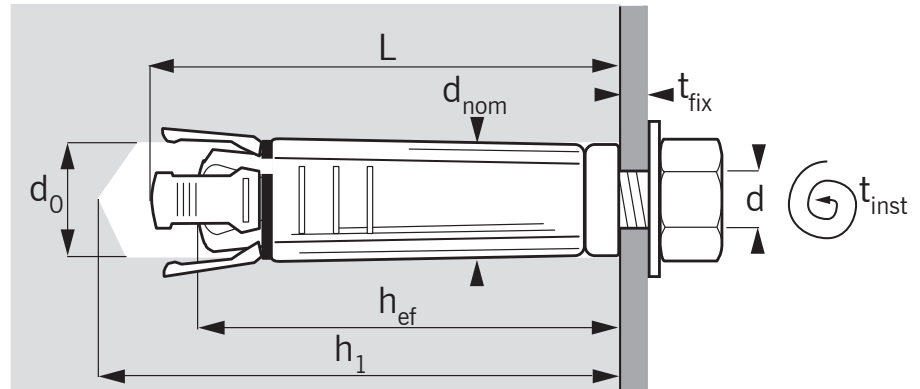

Type	Dimensions			Fixing								Load Capacities	
	d	d _{nom}	L	d ₀	h ₁	h _{ef}	h _{nom}	T _{inst}	h _{min}	S _{min}	C _{min}	N _{Rd}	V _{Rd}
Expandet Expansion shield	Bolt-diameter mm	Outside diameter of anchor mm	Anchor length mm	Drill hole diameter mm	Depth of drill hole (Min.) mm	Effective anchorage depth mm	Embedment depth mm	Required setting torque Nm	Thickness of concrete member, min. mm	Minimum spacing mm	Minimum edge distance mm	Design resistance Tension kN*	Design resistance Shear kN [◇]
HAC240	M 6	10	40	10	45	40	40	10	100	60	60	2,70	6,40
HAC250	M 8	14	50	14	55	50	50	25	100	75	75	5,00	9,90
HAC260	M10	16	60	16	65	60	60	50	120	90	90	6,70	18,40
HAC270	M12	20	80	20	85	80	80	85	160	120	120	8,80	26,40
HAC280*	M16	25	100	25	110	100	100	200	200	150	100	20,40	20,00

- * Not included in ETA-approval.
- ◆ Design resistance for tension is valid for a single anchor together with metric screw or threaded rod in 8.8 steel in non-cracked concrete C20/25 not influenced by edge distance and/or spacing: $C \geq C_{min}$ and $S \geq 3 h_{ef}$.
 $\Psi_{re,N} = 1$ (Normal reinforcement according to ETAG 001, Annex C - 5.2.2.4).
- ◇ Design resistance for shear is valid for a single anchor together with metric screw or threaded rod in 8.8 steel in non-cracked concrete $\geq C20/25$ not influenced by edge distance and/or spacing: $C \geq 10 h_{ef}$ and $S \geq 3 h_{ef}$.

Combined resistance shall be verified if both tension and shear actions are applied. Se "Principles for Fastening" page 5 (Verification Method 2)

Partial safety factor for material (γ_m) is included in accordance with product ETA. Partial safety factor for actions (γ_f) has to be applied in accordance with national building code. If no guidance for γ_f exists ETAG 001, Annex C recommends factor 1,35 for permanent actions and factor 1,5 for variable actions.

When calculating load capacities for anchors or anchorgroup use Expandet Calculation Software allowing for design with individual edge distance and spacing in accordance with ETAG 001, Annex C, Design Method A. Download Calculation Software for free at www.expandet.com.

Important: See Expandet's "Principles for fastening" for general information on fastening as well as information on limited liability.
(Can be downloaded at www.expandet.com)

Reduction factors for HAC280:

Reduction factor for edge distance	
Edge distance in mm	Reduction factor
100	0,65
120	0,72
160	0,86
200	1,00

Reduction factor for spacing		
Spacing in mm	Tension load	Shear load
150	1,00	0,75
180	1,00	0,80
240	1,00	0,90
300	1,00	1,00

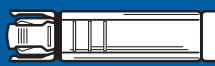

EXPANSION SHIELD

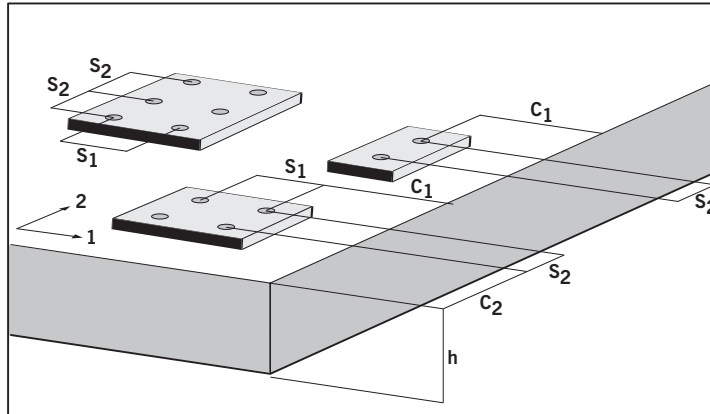

Design shear load capacities for a single anchor at minimum edge distance (C_{min})

Expansion shield	HAC240	HAC250	HAC260	HAC270
h_{nom} (embedment depth) mm	40	50	60	80
$V_{Rd,c}$ kN	3,1*	4,6*	6,6*	11,6*
C_{min} mm	60	75	90	120
S_{cr} mm	180	225	270	360

* Design shear load capacity is valid at minimum edge distance in concrete C20/25 providing that characteristic spacing is $\geq S_{cr}$.

Partial safety factor for edge failure (γ_{mc}) is included in accordance with product ETA.

Use Expandet Calculation Software for calculation of load capacities for single anchors and anchor groups in accordance with ETAG 001, Annex C – Design Method A.

Design shear load capacities (steel failure) and resistance against bending (lever arm) for Expansion shield HAC + metric thread in 8.8 steel

Expansion shield	HAC240	HAC250	HAC260	HAC270
$V_{Rd,s}$ kN	6,4*	11,2*	18,4*	26,4*
M_{Rd} Nm	9,6*	24,0*	48,0*	84,0*

* Design shear load capacity includes partial safety factor for material (γ_{ms}) in accordance with product ETA.

Use Expandet Calculation Software for calculation of load capacities for single anchors and anchor groups in accordance with ETAG 001, Annex C – Design Method A.



EXPANDET SCREW ANCHORS A/S
Svendebuen 2-6
P.O. Box 59
DK-3230 Græsted
Denmark

Telephone: +45 70 22 79 79
Telefax: +45 70 22 79 89

Version 06.012

www.expandet.com
expandet@expandet.dk

Graphic: Vedkom/Expandet
©Expandet Screw Anchors A/S, 2006
All rights reserved

EXPANDET SCREW ANCHORS A/S

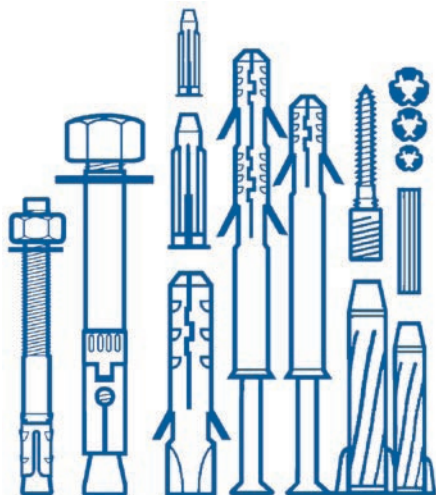

Expandet Screw Anchors A/S was established in 1955 and was pioneers in the field of fastener products for concrete and brickwork - being the first company to patent a fastener made in plastic. We are devoted to a constant development of our product range, which now covers the entire range of anchors and fasteners for both professional and DIY.

We have - with our base-material orientated colour code system - made it easy to choose the right anchor for the right base material

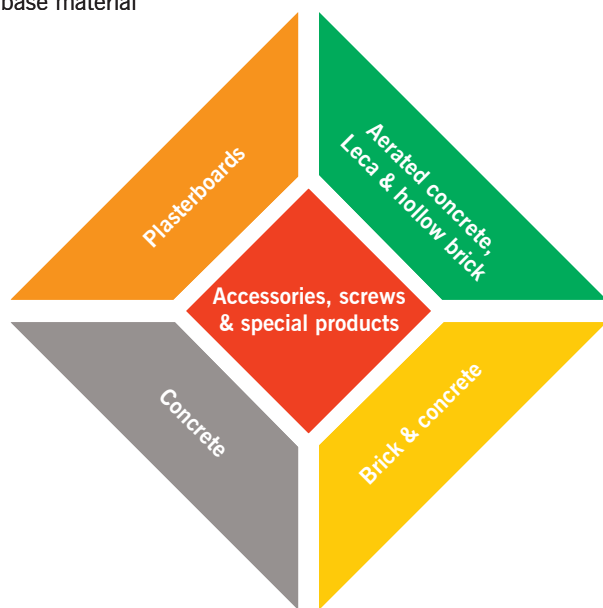

EXPANDET CALCULATION SOFTWARE

Expandet Calculation Software offers the possibility for design of single anchors and anchors groups in concrete according to ETAG 001, Annex C with our range of products that are defined according to CC Method. This includes our range of anchor systems approved for structural connections with CE-marking.

Code	Unit	Definition
d	Mx	Bolt diameter
d _{nom}	mm	Outside diameter of anchor
L	mm	Anchor length
L _{bolt}	mm	Bolt / screw length
L _{thread}	mm	Length of metric thread
L _{th}	mm	Available internal thread length
L _{smin}	mm	Minimum screw in depth
d _o	mm	Drill hole diameter
h _i	mm	Depth of drilled hole
h _{nom}	mm	Anchor embedment depth
h _{ef}	mm	Effective anchorage depth
h	mm	Thickness of member (concrete, brickwall etc.)
h _{min}	mm	Minimum thickness of member
h _f	mm	Minimum cavity behind wall
t _{fix}	mm	Thickness of fixture
b _{fix1,2}	mm	Width of fixture: b _{fix1} (direction 1) & b _{fix2} (direction 2)
T _{inst}	Nm	Required setting torque
S	mm	Spacing between anchors in an anchorage group
S ₁ ; S ₂	mm	Spacing between anchors in an anchorage group: S ₁ (direction 1) & S ₂ (direction 2)
S _{cr,N}	mm	Characteristic spacing for ensuring the transmission of the characteristic resistance of a single anchor in case of concrete cone failure
S _{cr,sp}	mm	Characteristic spacing for ensuring the transmission of the characteristic resistance of a single anchor in case of splitting failure
S _{rec}	mm	Recommended spacing (for full resistance)
S _{min}	mm	Minimum allowable spacing
S _{cr}	mm	Characteristic spacing at a defined edge distance
C	mm	Edge distance
C ₁ ; C ₂	mm	Edge distance fra anchor to edge: C ₁ (direction 1) & C ₂ (direction 2)
C _{cr,N}	mm	Characteristic edge distance for ensuring the transmission of the characteristic resistance of a single anchor in case of concrete cone failure
C _{cr,sp}	mm	Characteristic edge distance for ensuring the transmission of the characteristic resistance of a single anchor in case of splitting failure
C _{rec}	mm	Recommended edge distance (for full resistance)
C _{min}	mm	Minimum allowable edge distance
C _{cr}	mm	Characteristic edge distance at a defined spacing
N _{Rd}	kN	Design resistance, tension
N _{Rd,s}	kN	Design resistance, tension (steel failure)
N _{Rd,p}	kN	Design resistance, tension (pull out failure)
N _{Rd,c}	kN	Design resistance, tension (concrete cone failure)
N _{Rd,sp}	kN	Design resistance, tension (splitting failure)
V _{Rd}	kN	Design resistance, shear
V _{Rd,s}	kN	Design resistance, shear (steel failure)
V _{Rd,c}	kN	Design resistance, shear (concrete pryout failure, concrete edge failure)
F _{Rd}	kN	Design resistance, independent of load direction
M _{Rd}	Nm	Design resistance, bending moment
γ _M		Partial safety factor for material
γ _{Ms}		Partial safety factor for material, steel failure
γ _{Mp}		Partial safety factor for material, pull out failure
γ _{Mc}		Partial safety factor for material, concrete cone failure
γ _{Msp}		Partial safety factor for material, splitting failure
N _{Sd}	kN	Design value of tensile actions acting on a single anchor or the fixture of an anchor group
V _{Sd}	kN	Design value of shear actions acting on a single anchor or the fixture of an anchor group
γ _f		Partial safety factor for actions
N _{rec}	kN	Maximum recommended tension load
V _{rec}	kN	Maximum recommended shear load
F _{rec}	kN	Maximum recommended load, independent of load direction
f _{ck}	N/mm ²	Characteristic concrete compression strength measured on cylinders
f _{ck,cube}	N/mm ²	Characteristic concrete compression strength measured on cubes
F _{yk}	N/mm ²	Characteristic steel yield strength
F _{uk}	N/mm ²	Characteristic steel ultimate tensile strength



EXPANDET SCREW ANCHORS A/S
Svendebuen 2-6
P.O. Box 59
DK-3230 Græsted
Denmark

Telephone: +45 70 22 79 79
Telefax: +45 70 22 79 89

Version 06.012

www.expandet.com
expandet@expandet.dk

Graphic: Vedkom /Expandet
©Expandet Screw Anchors A/S, 2006
All rights reserved